

WHITE PAPER

# How to Select Your Next Oscilloscope: 12 Tips on What to Consider Before You Buy

## Introduction

You rely on your oscilloscope every day, so selecting the right one to meet your specific measurement needs and budget is an important task. Comparing different manufacturers' oscilloscopes and their various specifications and features can be time-consuming and confusing. The 12 oscilloscope selection tips presented in this white paper can help you accelerate your selection process and avoid some common pitfalls.

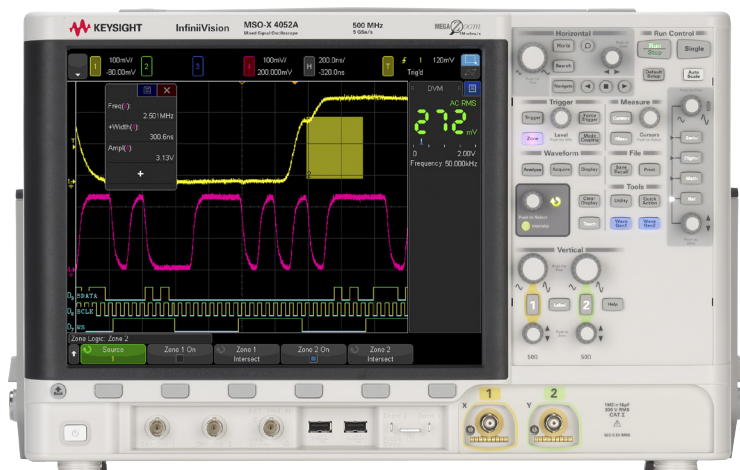

## Tip #1: Bandwidth

### Select an oscilloscope that has sufficient bandwidth to accurately capture the highest-frequency content of your signals

A variety of oscilloscope specifications determine how accurately signals can be captured and measured. But an oscilloscope's primary specification is its bandwidth. So what do we mean by "bandwidth"?

All oscilloscopes exhibit a low-pass frequency response that rolls off at higher frequencies, as shown in Figure 1. Most oscilloscopes with bandwidth specifications of 1 GHz and below have a Gaussian frequency response, which approximates the characteristics of a single-pole low-pass filter. The lowest frequency at which the input signal is attenuated by 3 dB is considered the oscilloscope's bandwidth. Signal attenuation at the -3 dB frequency translates into approximately -30% amplitude error. In other words, if you input a 1 Vpp, 100 MHz sine wave into a 100 MHz bandwidth oscilloscope, the measured peak-to-peak voltage using this oscilloscope would be in the range of 700 mVpp (-3 dB =  $20 \text{ Log}(0.707/1.0)$ ). So you cannot expect to make accurate measurements on signals that have significant frequencies near your oscilloscope's bandwidth.

So how much bandwidth do you need for your particular measurement applications? For purely analog signal measurements, you should choose an oscilloscope that has a bandwidth specification at least three times higher than the highest sine wave frequencies you may need to measure.

At one-third of an oscilloscope's bandwidth specification, signal attenuation is minimal. But what about required bandwidth for digital applications, the main use of today's oscilloscopes? As a general rule, Keysight Technologies recommends you choose an oscilloscope with a bandwidth at least five times the highest clock rate in your systems. For example, if the highest clock rate in your designs is 100 MHz, then you should choose an oscilloscope with a bandwidth of 500 MHz or higher. If your oscilloscope meets this criterion, it will be able to capture up to the fifth harmonic with minimum signal attenuation. The fifth harmonic of the signal is critical in determining the overall shape of your digital signals.

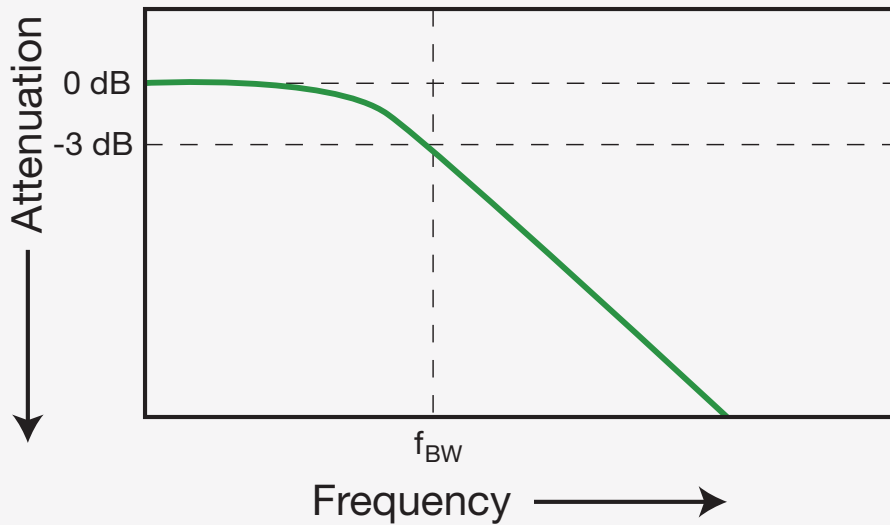

Figure 1. Oscilloscopes exhibit a low-pass frequency response that rolls off higher frequencies

Figure 2 shows a 100 MHz bandwidth oscilloscope capturing and displaying a 100 MHz digital clock signal. In this case, the oscilloscope attenuates the higher-frequency components and basically just shows the 100 MHz sine wave fundamental frequency of this signal. This oscilloscope has insufficient bandwidth to capture this signal. Figure 3 shows the same 100 MHz clock signal captured on a 500 MHz bandwidth oscilloscope. We can now see and measure more details of this digital signal using this higher-bandwidth oscilloscope.

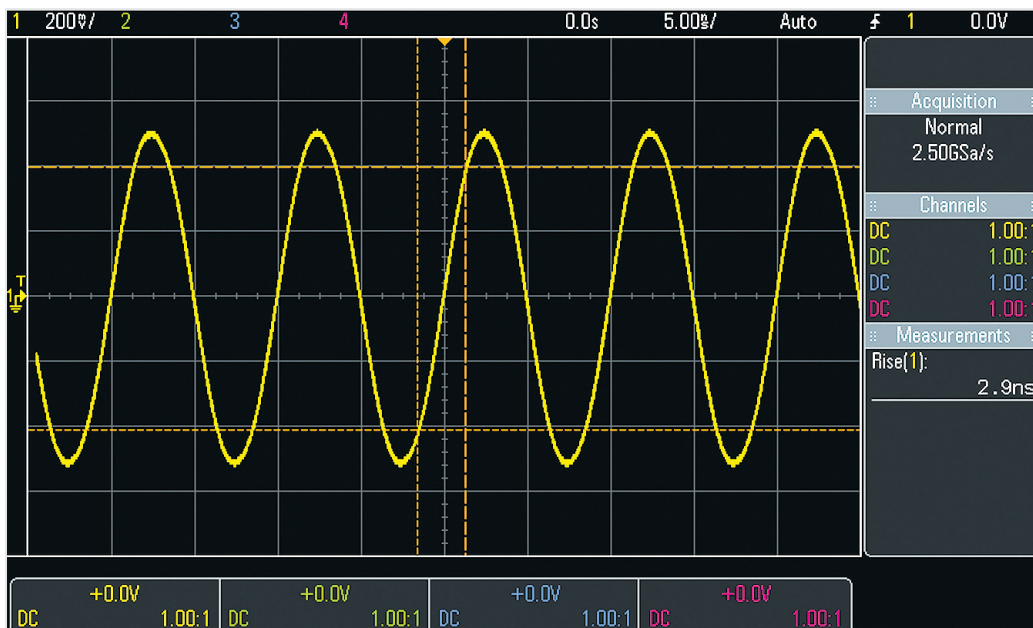

Figure 2. 100 MHz clock signal captured on a 100 MHz bandwidth oscilloscope

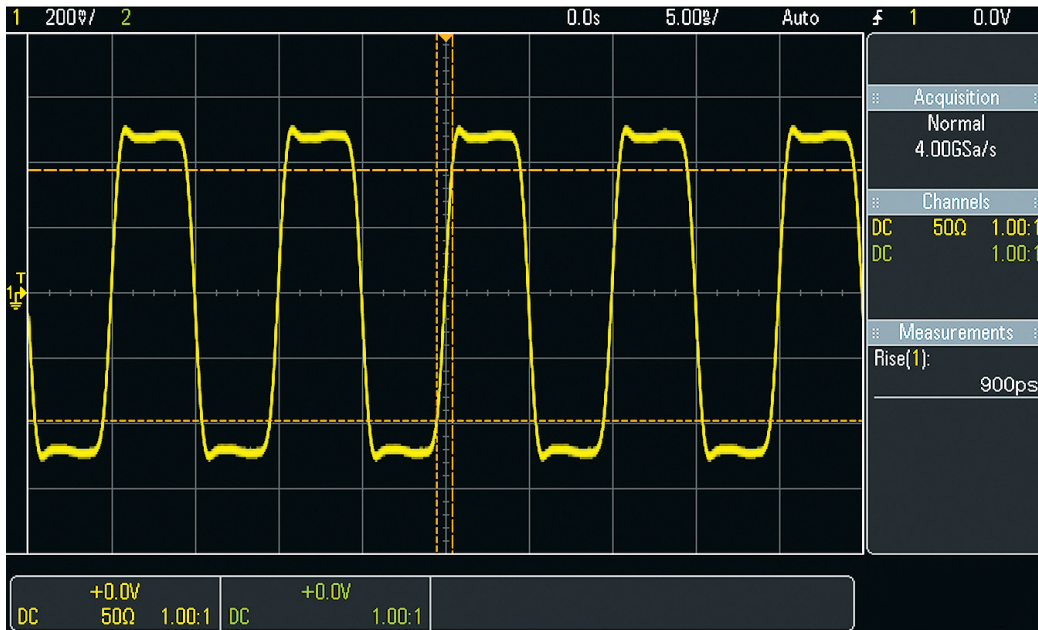

Figure 3. 100 MHz clock signal captured on a 500 MHz bandwidth oscilloscope

Note that the 5-to-1 recommendation (oscilloscope bandwidth relative to clock rate) does not take into account lower clock-rate signals that have relatively fast edge speeds. These signals may contain significant frequency components beyond the fifth harmonic. To learn more about how to determine required bandwidth based on signal edge speeds, refer to the Keysight application note [Evaluating Oscilloscope Bandwidths for Your Applications](#).

## Protect your investment with bandwidth upgradability

Keysight Technologies' InfiniiVision and Infiniium Series oscilloscopes come in bandwidths ranging from 50 MHz to 110 GHz. You can also upgrade the bandwidths after the initial purchase. This protects your oscilloscope investment. Perhaps a 100 MHz bandwidth oscilloscope is all you need and can afford today. However, if your signal speeds increase in two years, you may then need a 500 MHz oscilloscope to make accurate measurements on your higher-speed designs. No problem.

## Tip #2: Sample Rate

### Select an oscilloscope that has a maximum specified sample rate fast enough to deliver its specified real-time bandwidth

Closely related to an oscilloscope's real-time bandwidth is its maximum specified sample rate. "Real time" simply means the oscilloscope can capture and display signals commensurate with its specified bandwidth in a single acquisition (not repetitive).

Most engineers are familiar with Nyquist's sampling theorem. The theorem states that for a limited-bandwidth (band-limited) signal with maximum frequency  $f_{\max}$ , the equally spaced sampling frequency  $f_s$  must be greater than twice the maximum frequency  $f_{\max}$  — that is,  $f_s > 2 \cdot f_{\max}$  — for the signal to be uniquely reconstructed without aliasing.

Today  $f_{\max}$  is commonly known as the Nyquist frequency ( $f_N$ ). Some engineers mistakenly assume  $f_{\max}$ , or  $f_N$ , is the same as  $f_{BW}$  (oscilloscope bandwidth). With this assumption, you might think the minimum required sample rate for an oscilloscope of a particular specified bandwidth is just twice the oscilloscope's real-time bandwidth specification, as shown in Figure 4. But  $f_{\max}$  is not the same as  $f_{BW}$ , unless the oscilloscope had a brick-wall filter response.

As you learned in Tip #1, oscilloscopes with bandwidth specifications of 1 GHz and below typically have a Gaussian frequency response. This means that, although the oscilloscope attenuates the amplitude of signal frequencies above its  $-3$  dB bandwidth frequency point, it does not eliminate these higher-frequency components. The red hashed area in Figure 4 shows the aliased frequency components. Therefore,  $f_{\max}$  is always higher than  $f_{BW}$  for an oscilloscope.



Dr. Harry Nyquist

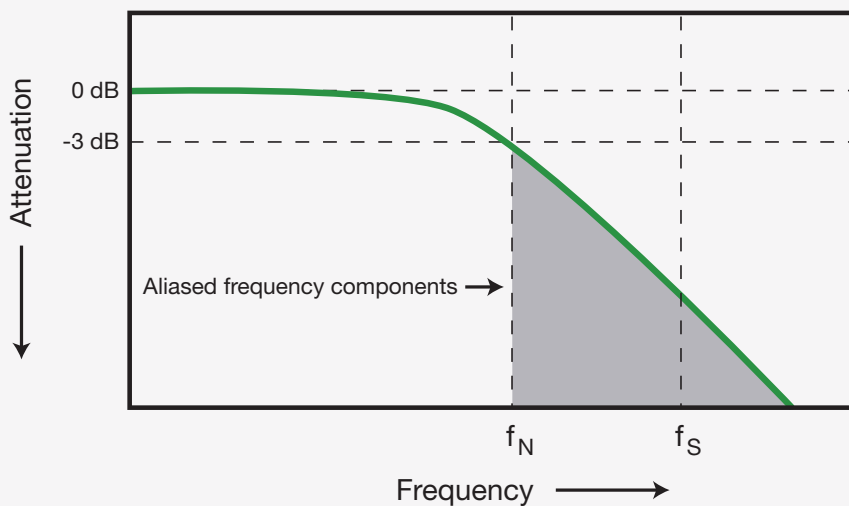

Figure 4. Aliased frequency components when the oscilloscope's bandwidth is specified at half its sample rate for oscilloscopes that exhibit a Gaussian frequency response

Keysight recommends that an oscilloscope's maximum specified sample rate should be at least four to five times higher than the scope's specified real-time bandwidth, as shown in Figure 5. With this criterion, the oscilloscope's  $\sin(x)/x$  waveform reconstruction filter can accurately reproduce the wave shape of higher-speed signals with resolution in the tens-of-picoseconds range.

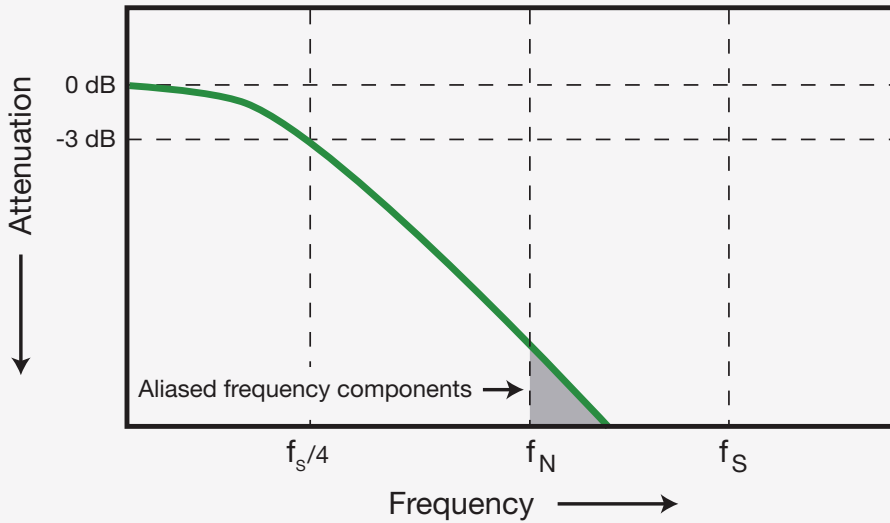

Figure 5. Aliased frequency components when the oscilloscope's bandwidth is specified at one-fourth the oscilloscope's sample rate

Many higher-bandwidth oscilloscopes have a faster or sharper roll-off frequency response, as shown in Figure 6. We call this type of frequency response a “maximally flat” response. An oscilloscope with a maximally flat response attenuates frequency components beyond the Nyquist frequency to a higher degree and begins to approach the ideal characteristics of a theoretical brick-wall filter. Therefore, you do not need as many samples to produce a good representation of the input signal while using digital filtering to reconstruct the waveform. Oscilloscopes with this type of frequency response can theoretically specify the bandwidth at  $f_s/2.5$ .

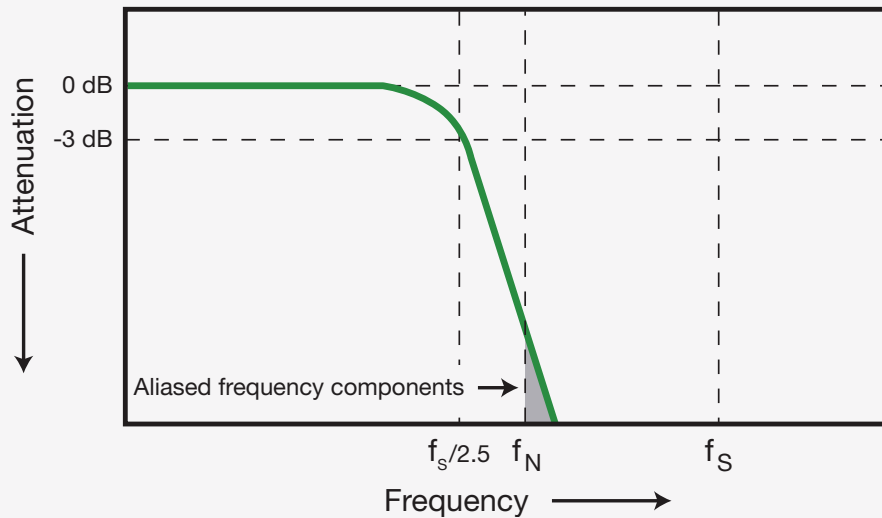

Figure 6. Aliased frequency components when the oscilloscope's bandwidth is specified at 1/(2.5) of the scope's sample rate for oscilloscopes that exhibit a "maximally flat" frequency response

To learn more about oscilloscope real-time sampling, refer to the Keysight application note [Evaluating Oscilloscope Sample Rates Versus Sampling Fidelity](#).

The core component of all digital storage oscilloscopes is the high-speed analog-to-digital converter (ADC) system. Keysight invests heavily in ADC technology and has the highest sample rate and highest-fidelity monolithic ADCs in the oscilloscope industry. Keysight's InfiniiVision 3000T X Series oscilloscopes can sample at rates up to 5 GSa/s, while Keysight's higher-performance UXR-Series oscilloscopes can sample at rates up to 256 GSa/s.

### Tip #3: Memory Depth

**Select an oscilloscope that has sufficient acquisition memory to capture your most complex signals with high resolution**

Closely related to an oscilloscope's maximum sample rate is its maximum available acquisition memory depth. An oscilloscope's banner specifications may list a high maximum sample rate, but this does not mean that the oscilloscope always samples at this high rate. Oscilloscopes sample at their fastest rates when the timebase is set on one of the faster time ranges. But when the timebase is set to slower ranges to capture longer time spans across the oscilloscope's display, the scope automatically reduces the sample rate based on the available acquisition memory.

For example, let's assume that an entry-level oscilloscope has a maximum sample rate of 1 GSa/s and a memory depth of 10 k points. If the oscilloscope's timebase is set at 10 ns / div to capture 100 ns of signal activity across the oscilloscope's screen (10 ns / div x 10 divisions = 100 ns time span), the oscilloscope needs just 100 points of acquisition memory to fill the screen while sampling at its maximum sample rate of 1 GSa/s (100 ns time span x 1 GSa/s = 100 samples). No problem. But if you set the oscilloscope's timebase to 10  $\mu$ s / div to capture 100  $\mu$ s of signal activity, the oscilloscope will automatically reduce its sample rate to 100 MSa/s (10 k samples/100  $\mu$ s time span = 100 MSa/s). The oscilloscope must have additional acquisition memory to maintain the fastest sample rate at the slower timebase. Determining the amount of acquisition memory you require involves a pretty simple equation based on the longest time span of a complex signal you need to capture and the maximum sample rate at which you want the oscilloscope to sample.

$$\text{Acquisition memory} = \text{time span} \times \text{required sample rate}$$

Figure 7 shows a Keysight InfiniiVision 3000T X-Series oscilloscope capturing a complex digital signal at 100  $\mu$ s / div for a total capture time of 1 ms. Since this oscilloscope has up to 4 million points of acquisition memory, it can maintain its maximum sample rate of 4 GSa/s at this timebase setting. In the upper half of the oscilloscope's display, we can see the entire captured waveform. In the lower half of the oscilloscope's display, we can see a "zoomed-in" display of a small portion of the captured waveform, revealing a runt pulse that is approximately 100 ns wide.

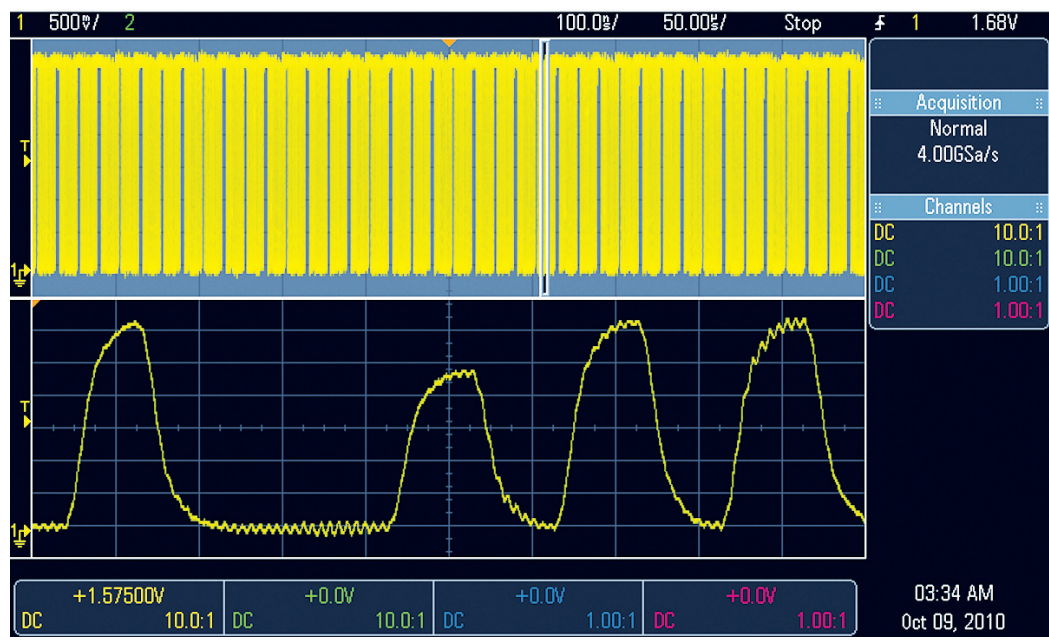

Figure 7. Capturing a complex stream of digital pulses using deep memory



Although you may intuitively think deeper is always better, using deep memory often means making trade-offs. First, oscilloscopes with deep memory typically have a higher price. Second, acquiring long waveforms using deep memory requires additional waveform processing time. This typically means reduced waveform update rates, sometimes significant. For this reason, most oscilloscopes on the market have manual memory-depth selections, and the typical default memory depth setting is relatively shallow (10 to 100 k). If you want to use deep memory, then you must manually turn it on and deal with the update rate trade-off. This means you must know when it is important to use deep memory and when it is not.

With Keysight's exclusive MegaZoom technology, you don't have to be an oscilloscope expert. MegaZoom automatically selects deeper memory when needed to maintain fast sample rates. And with this custom technology, the oscilloscope always remains responsive — even when using deep memory.

## Segmented memory

Some oscilloscopes have a special mode of operation called “segmented memory acquisition.” Segmented memory can effectively extend the oscilloscope's total acquisition time by dividing its available acquisition memory into smaller memory segments, as illustrated in Figure 8. The oscilloscope then selectively digitizes just the important portions of the waveform under test at a high sample rate and time-tags each segment so you know the precise time between each occurrence of trigger events. This process enables your oscilloscope to capture many successive single-shot waveforms with a very fast rearm time — without missing important signal information. This mode of operation is especially useful when capturing a burst of signals. Examples of burst-type signals include pulsed radar, laser bursts, and packetized serial bus signals.

To learn more about oscilloscope segmented memory acquisition, refer to the Keysight application note [Using Oscilloscope Segmented Memory for Serial Bus Applications](#).

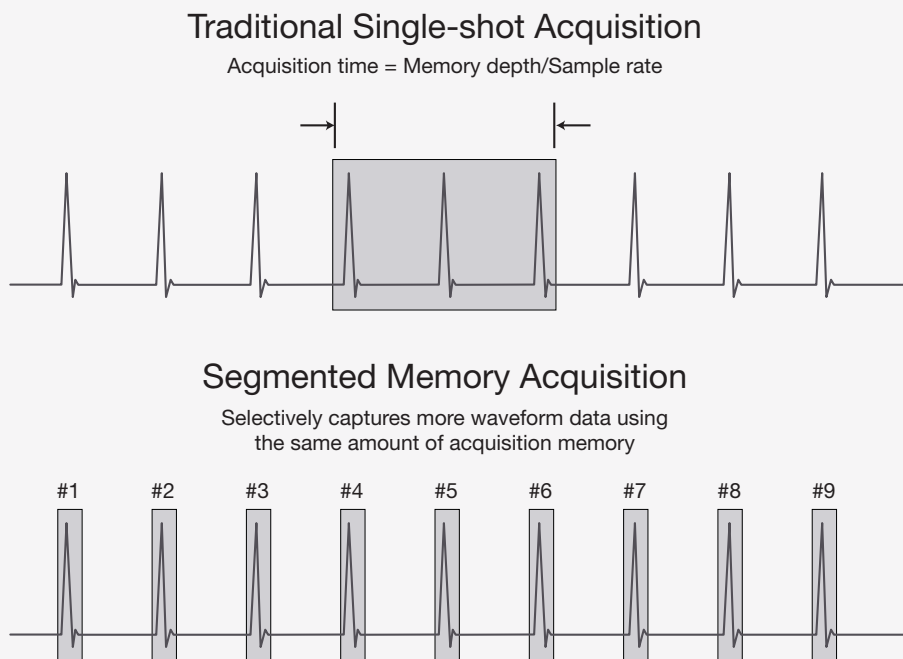

Figure 8. Visual of how segmented memory works

Segmented memory acquisition is available on all of Keysight's InfiniiVision X-Series and Infiniium Series oscilloscopes. When you need the absolute deepest memory, Keysight's Infiniium Series oscilloscopes offer up to 2 GB of acquisition memory so you can capture the longest time span at the oscilloscope's maximum sample rate.

## Tip #4: Number of Channels

**Select an oscilloscope that has a sufficient number of channels of acquisition so that you can perform critical time-correlated measurements across multiple waveforms**

The number of oscilloscope channels you require will depend on how many signals you need to observe and compare in relation to each other. At the heart of most of today's embedded designs is a microcontroller (MCU), as shown in the simplified schematic of Figure 9. Many MCUs are actually mixed-signal devices with multiple analog, digital, and serial input / output (I/O) signals that interface to the real world, which is always analog.

As mixed-signal designs become more complex, you may require more channels of acquisition and display. Two-, four-, and eight-channel oscilloscopes are common. If you need more than eight analog channels of acquisition, your choices become limited. (Keysight does offer solutions such as the [N8834A MultiScope application](#), which allows you to tie multiple oscilloscopes together.) But there is another alternative: a mixed-signal oscilloscope (MSO).

MSOs combine all the measurement capabilities of oscilloscopes with some of the measurement capabilities of logic analyzers and serial bus protocol analyzers. MSOs have three primary attributes. The most obvious attribute is the ability to simultaneously capture multiple oscilloscope and logic signals with a time-correlated display of waveforms. Think of it as having a few channels with high vertical resolution (typically 8 bits) plus several additional channels with very low vertical resolution (1 bit).

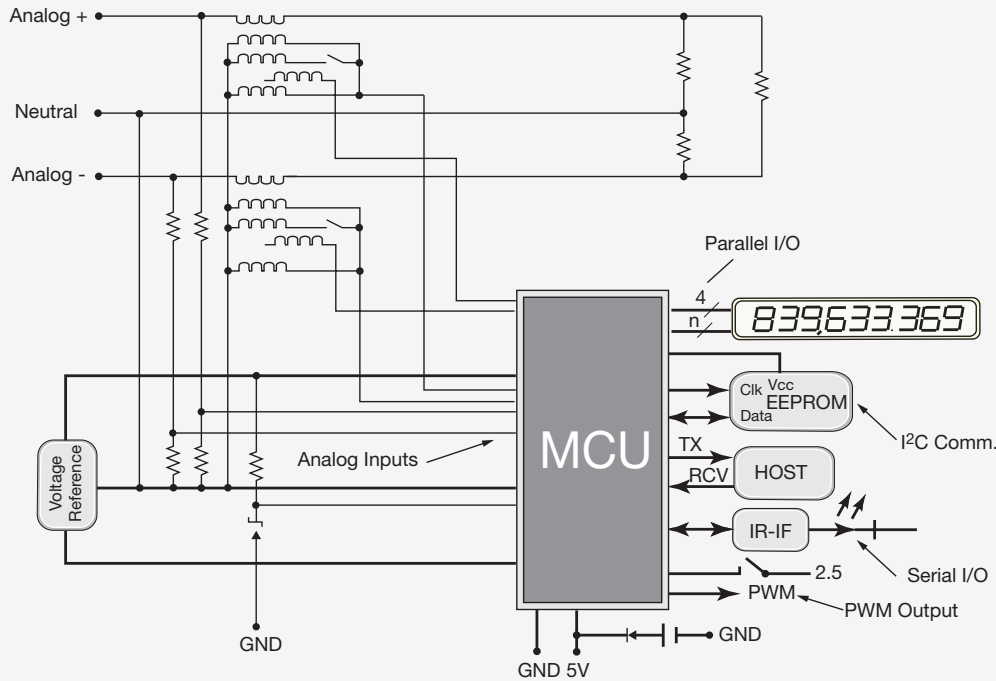

Figure 9. Typical MCU-based embedded design

Another attribute: although an MSO may lack the large number of digital channels of a logic analyzer, one of its primary advantages is its familiar oscilloscope use model. And finally, with the additional logic channels available in MSOs, users have many more triggering possibilities that they can use to “zero-in” on specific parallel and serial bus I/O interaction in today’s mixed-signal designs.

Some oscilloscope vendors make you choose between using each channel input as either one analog channel or multiple digital logic inputs (MSO capability). This gives you flexibility, but it also means you are occupying an analog channel when trying to use the MSO functionality. Keysight oscilloscopes give you the best of both worlds, combining two, four, or eight dedicated analog channels with eight or 16 dedicated MSO channels, depending on the oscilloscope family.

Figure 10 shows a Keysight MSO capturing the input of an MCU-controlled digital-to-analog converter (DAC) using its digital channels of acquisition while monitoring the output of the DAC with a single analog channel of acquisition. In this example, the MSO was set up to trigger on a logical pattern condition of the input of the DAC when it was at its lowest value of 0000 1010 (1  $A_{HEX}$ ).

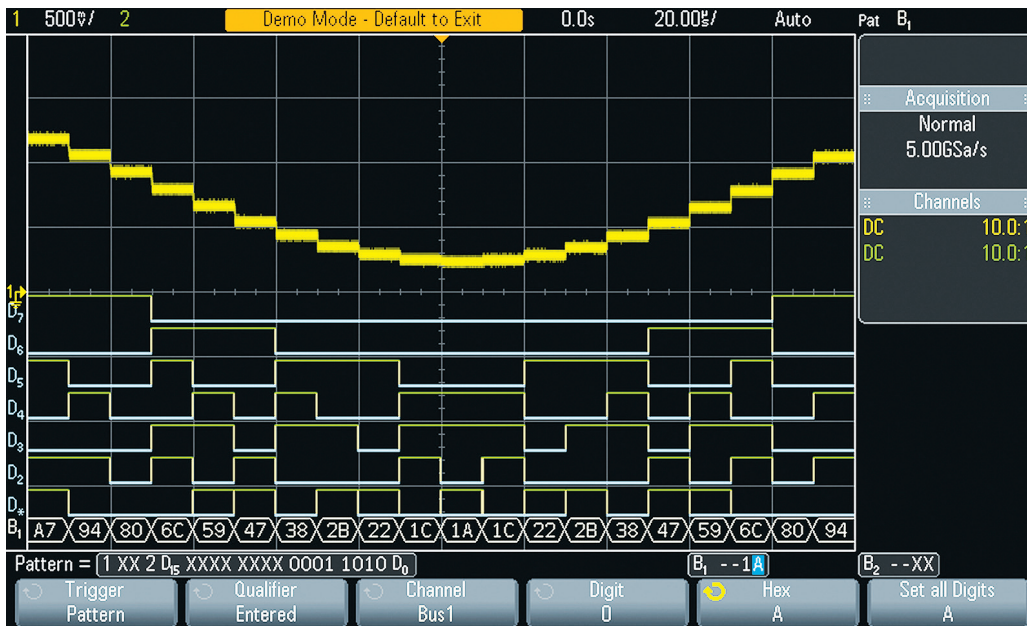

Figure 10. MSOs can capture and display multiple analog and digital signals simultaneously, providing an integrated and time-correlated display of multiple waveforms

To learn more about making measurements with an MSO, please see the [Evaluating Oscilloscopes to Debug Mixed-Signal Designs](#) application note.

Keysight’s InfiniiVision and Infiniium oscilloscopes can be preconfigured and purchased as either digital storage oscilloscope (DSOs) or MSO models. You can easily upgrade DSO models to MSO models after purchase.

## Tip #5: Waveform Update Rate

**Select an oscilloscope that has a fast enough waveform update rate to capture random and infrequent events to help you debug your designs faster**

Although often overlooked when evaluating the performance of various oscilloscopes for purchase, waveform update rates can be essential — sometimes just as important as traditional banner specifications of bandwidth, sample rate, and memory depth. While the update rate may appear fast when viewing repetitively captured waveforms on your oscilloscope’s display, “fast” is relative. For example, a few hundred waveforms per second will certainly appear lively. Statistically speaking, however, this can be very slow if you are attempting to capture a random and infrequent event that may happen just once in a million occurrences of a signal.

Waveform update rates can be critical when you debug new designs — especially when you are attempting to find and debug infrequent or intermittent problems. These are the toughest kinds of problems to solve. Faster waveform update rates improve the oscilloscope’s probability of capturing elusive events.

All oscilloscopes have an inherent characteristic called “dead time” or “blind time.” This is the time between each repetitive acquisition of the oscilloscope when it is processing the previously acquired waveform. Unfortunately, oscilloscope dead times can be orders of magnitude longer than acquisition times. During dead time, the oscilloscope will miss any signal activity that may be occurring, as shown in Figure 11. Note the two glitches that occurred during the oscilloscope’s dead time — not during its acquisition time.

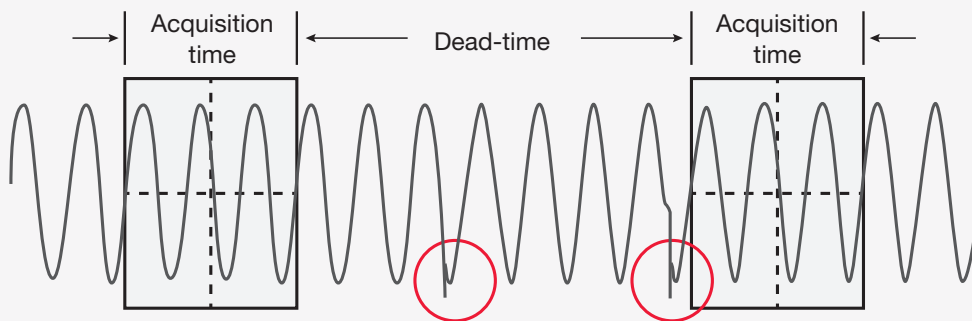

Figure 11. Oscilloscope dead time versus display acquisition time

Because of dead time, capturing random and infrequent events with an oscilloscope becomes a gamble — much like rolling dice. The more times you roll the dice, the higher the probability of obtaining a specific combination of numbers. Likewise, the more often an oscilloscope updates waveforms for a given amount of observation time, the higher the probability of capturing and viewing an elusive event — one that you may not even know exists.

Figure 12 shows a Keysight InfiniiVision X-Series oscilloscope capturing an infrequent metastable state (glitch) that occurs approximately five times per second. With a maximum waveform update rate of more than 1 million waveforms per second, the oscilloscope has a 92% probability of capturing this glitch within 5 seconds. In this example, the oscilloscope captured the metastable state several times.

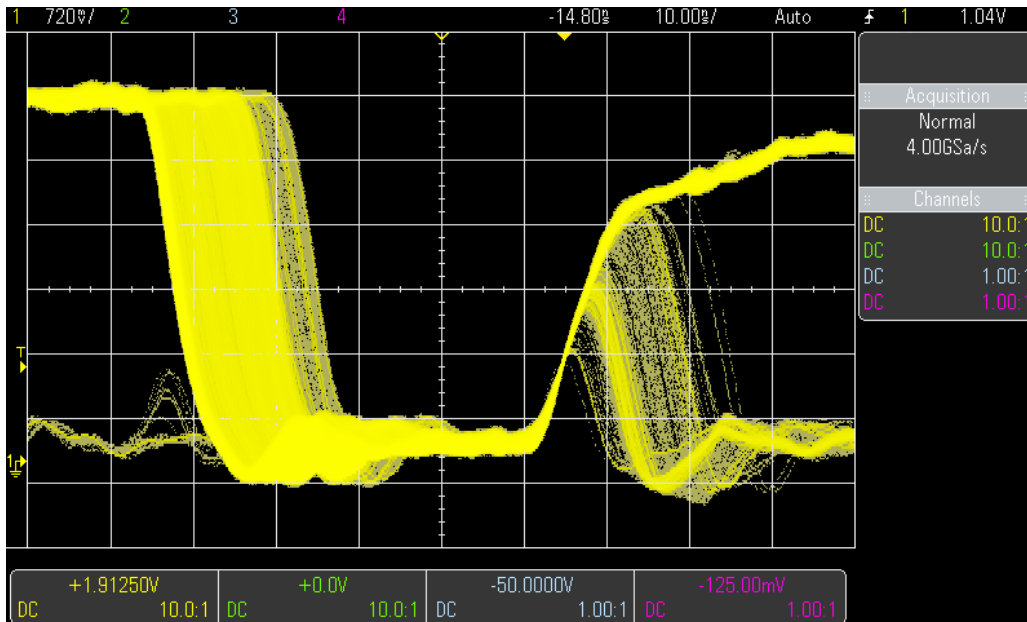

Figure 12. The Keysight MSO / DSO 3000 X-Series oscilloscope reliably captures the infrequently occurring metastable state while updating at 1 million waveforms per second

Other oscilloscopes in this class may update waveforms only 2,000 to 3,000 times per second. Those oscilloscopes would have less than a 1% probability of capturing and displaying an infrequent glitch such as this within 5 seconds. To learn more about oscilloscope waveform update rates and how to compute statistical glitch capture probabilities, refer to the Keysight application note, [Can Your Oscilloscope Capture Elusive Events?](#)

## Tip #6: Triggering

**Select an oscilloscope that has the types of advanced triggering that you may need to help you isolate waveform acquisitions on your most complex signals**

An oscilloscope's triggering capability is one of its most important aspects. Triggering allows you to synchronize the oscilloscope's acquisition and display of waveforms on particular parts of a signal. You can think of oscilloscope triggering simply as synchronized picture taking.

Triggering on a simple edge crossing is most common. For example, trigger on a rising edge of channel 1 when the signal crosses a particular voltage level (trigger level) in a positive direction, as shown in Figure 13. All oscilloscopes have this capability. But as today's digital designs have become more complex, you may need to further qualify or filter your oscilloscope's triggering on particular characteristics or combinations of input signals to zero in on, capture, and view a particular portion of a complex input signal.

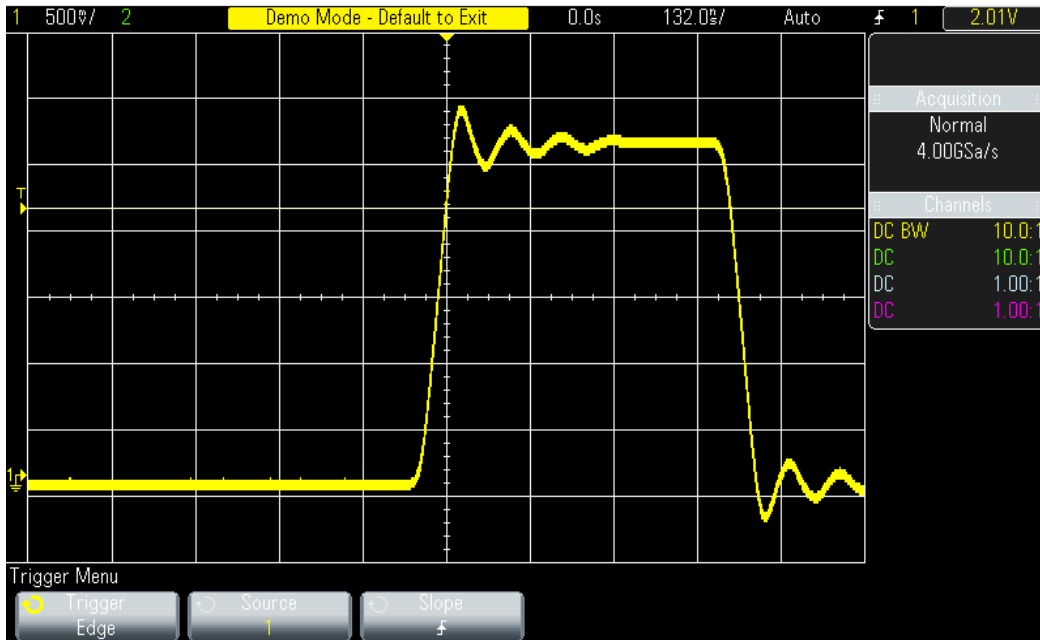

Figure 13. Triggering on a rising edge of a digital pulse

Some oscilloscopes can trigger on pulses that meet a particular timing qualification — for example, trigger only when a pulse is less than 20 ns wide. This type of triggering (qualified pulse-width) can be useful for unsuspected glitches.

Pattern triggering is another common type. Pattern triggering allows you to set up the oscilloscope to trigger on a logical / Boolean combination of highs (or 1s) and lows (or 0s) across two or more input channels. This can be especially useful when using an MSO, which can provide up to 20 analog and digital channels of acquisition.

More advanced oscilloscopes even provide triggering that can synchronize on signals that have parametric violations. In other words, trigger only if the input signal violates a particular parametric condition, such as reduced pulse height (runt trigger), edge speed violation (rise / fall time), or perhaps a clock-to-data timing violation (setup and hold time trigger).

Figure 14 shows a Keysight oscilloscope triggering on a positive pulse with reduced amplitude using the runt triggering selection. If this runt pulse occurred just once in a million cycles of the digital pulse stream, capturing this signal while using standard edge triggering would be like looking for a needle in a haystack. This scope can also trigger on negative runts and runt pulses of a specific pulse width.

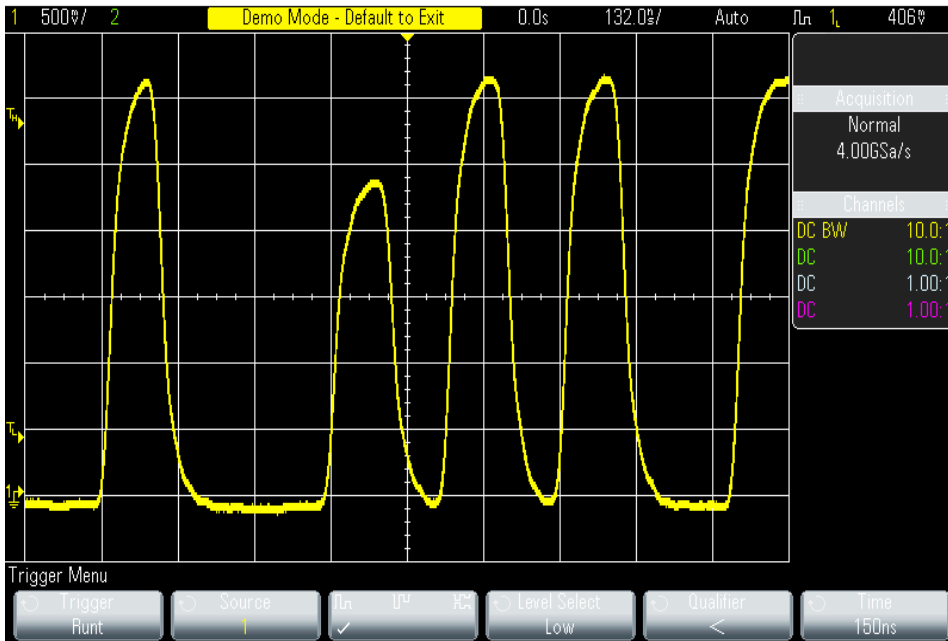

Figure 14. Triggering on a reduced amplitude pulse using runt triggering

Even with the advanced parametric triggering capability in an oscilloscope, determining which special trigger mode to select and how to set it up can be confusing. This is where Keysight's hardware-based zone touch trigger steps in. Figure 15 shows an example of an infrequent non-monotonic edge while the oscilloscope is set up to trigger on any rising edge of the input signal.



Figure 15. The oscilloscope's fast waveform update rate reveals an infrequent non-monotonic edge



With touch trigger, you can simply draw a box (zone) in the region of the anomaly, and the oscilloscope isolates just the infrequently occurring edges with the non monotonic edge, as shown in Figure 16.

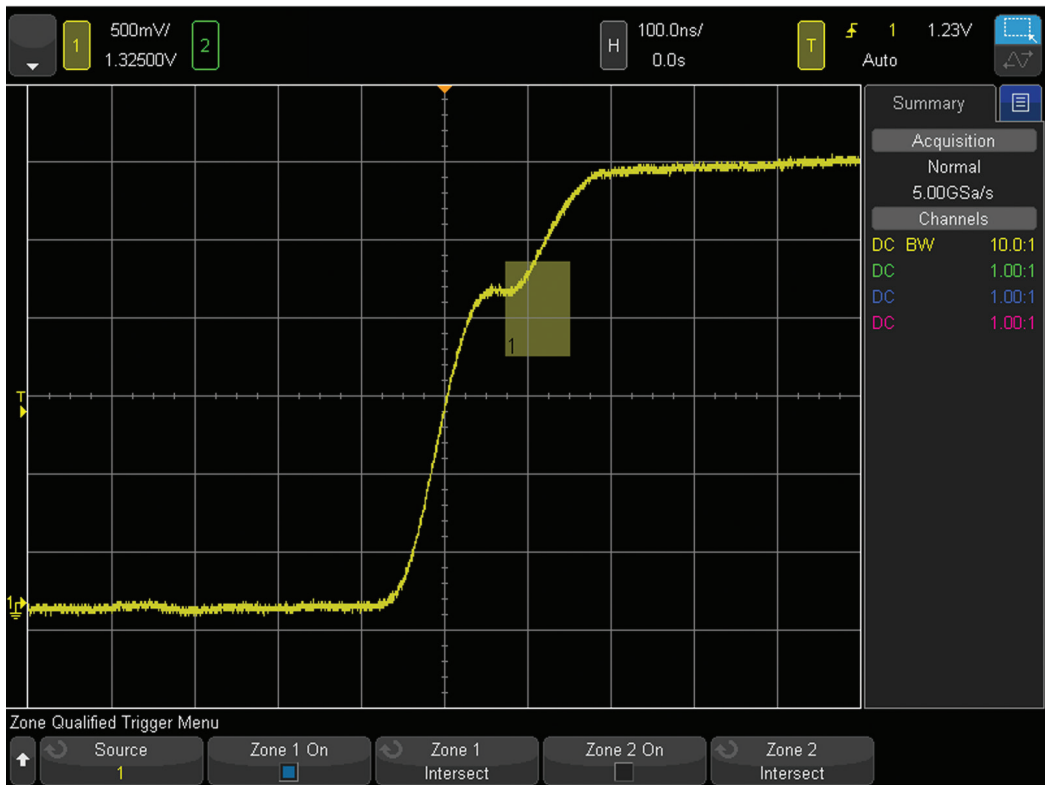

Figure 16. Touch trigger isolates the infrequent non monotonic edge

To learn more about touch triggering, refer to the Keysight application note [Triggering on Infrequent Anomalies and Complex Signals Using Zone Trigger](#).

## Tip #7: Display Quality

**Select an oscilloscope that provides multiple levels of trace intensity gradation to display subtle waveform details and signal anomalies**

The quality of your oscilloscope's display can make a big difference in your ability to effectively troubleshoot your designs. If your oscilloscope has a low-quality display, you may not be able to see subtle waveform details. An oscilloscope that is capable of showing signal intensity gradations can reveal important waveform details in a variety of analog and digital signal applications, including relative distribution of noise, jitter, and signal anomalies.

Engineers have traditionally thought of DSOs as two-dimensional instruments that graphically display just voltage versus time. But there is a third dimension to an oscilloscope: the z-axis. This third dimension shows continuous waveform intensity gradation as a function of the frequency of occurrence of signals at particular X-Y locations.

In analog oscilloscope technology, intensity modulation is a natural phenomenon of the oscilloscope's vector-type display, which is swept with an electron beam. Because of the early limitations of digital display technology, this third dimension, intensity modulation, was missing when digital oscilloscopes began replacing their analog counterparts. But some of today's DSOs now provide similar — and sometimes superior — display quality using custom digital signal processing technology.

Figure 17 shows a Keysight InfiniiVision X-Series oscilloscope that is set up to monitor jitter on a digital signal. With the oscilloscope's fast waveform update rate (up to 1 million waveforms / sec), along with 64 levels of trace intensity gradation, we can make qualitative judgments about the nature of the distribution of noise and jitter. We know traces that appear bright occur most often, while traces that appear dim occur least often.

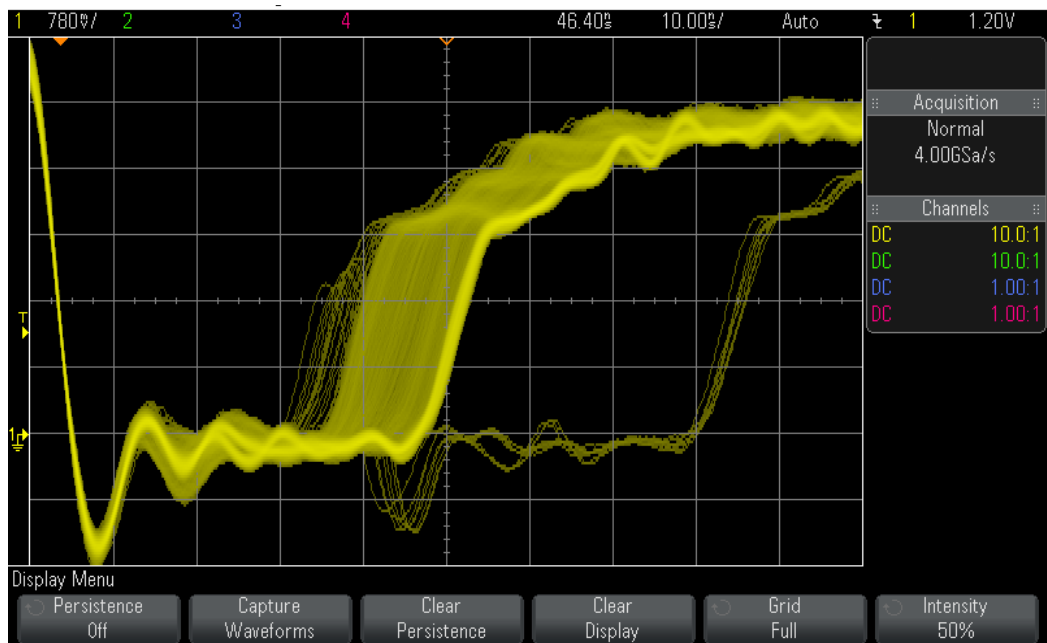

Figure 17. Multiple levels of trace intensity gradation reveals jitter distribution

First-generation DSOs, as well as most of today's entry-level oscilloscopes, provide just one or two levels of trace intensity gradation, as shown in Figure 18. This makes it impossible to make qualitative judgments about complex signal modulation since all traces have the same intensity. Does the jitter have a Gaussian or even distribution? Does the jitter include deterministic components? We don't know.

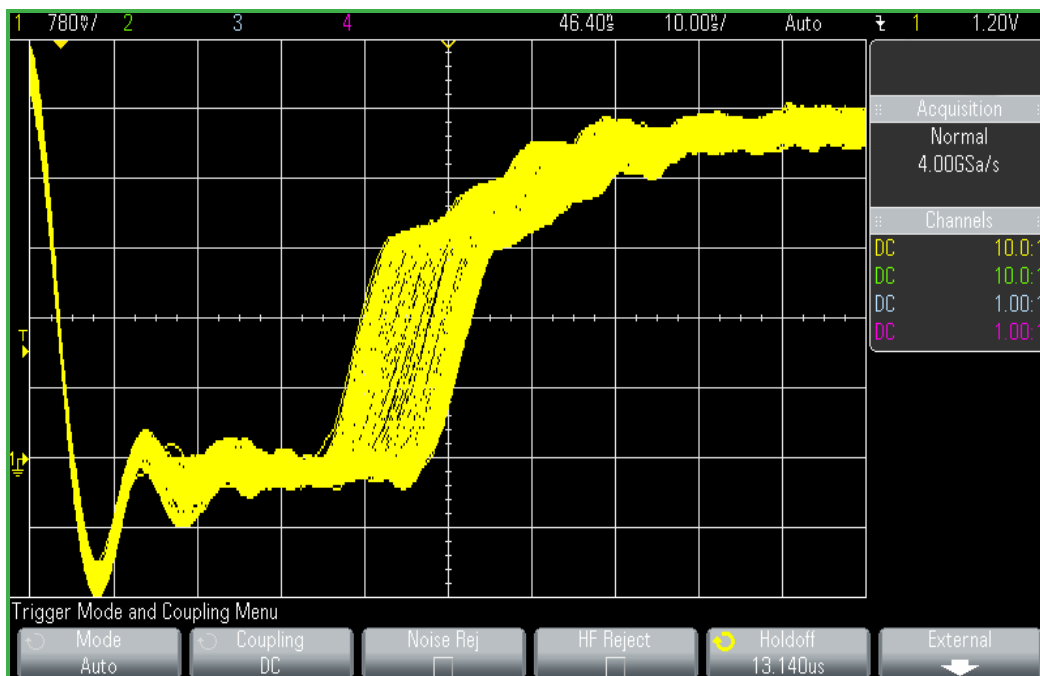

Figure 18. Most entry-level scopes provide just one or two levels of trace intensity gradation

Trace intensity gradation is also important when capturing and monitoring complex modulated analog signals, such as video. Figure 19 shows an InfiniiVision X-Series oscilloscope displaying three fields of an NTSC video signal, along with a zoomed-in display of a single line of interlaced video.

Oscilloscopes also come in different form factors so you can optimize display size versus other considerations. For example, if you prefer a large display to be able to easily see multiple signals on the screen, the Keysight InfiniiVision 4000 X-Series / 6000 X-Series and the Infiniium S-Series / MXR-Series offer large 12.1-inch or 15.6-inch displays. On the other hand, if bench space or vertical space is something you want to minimize, the Keysight InfiniiVision 1000 X-, 2000 X-, or 3000T X-Series would better suit your needs.

In addition to the number of levels of trace intensity gradation, you should consider other display quality factors. They include update rate, display size, display resolution, viewing angle, color versus monochrome, and user-selectable display modes such as variable and infinite persistence.

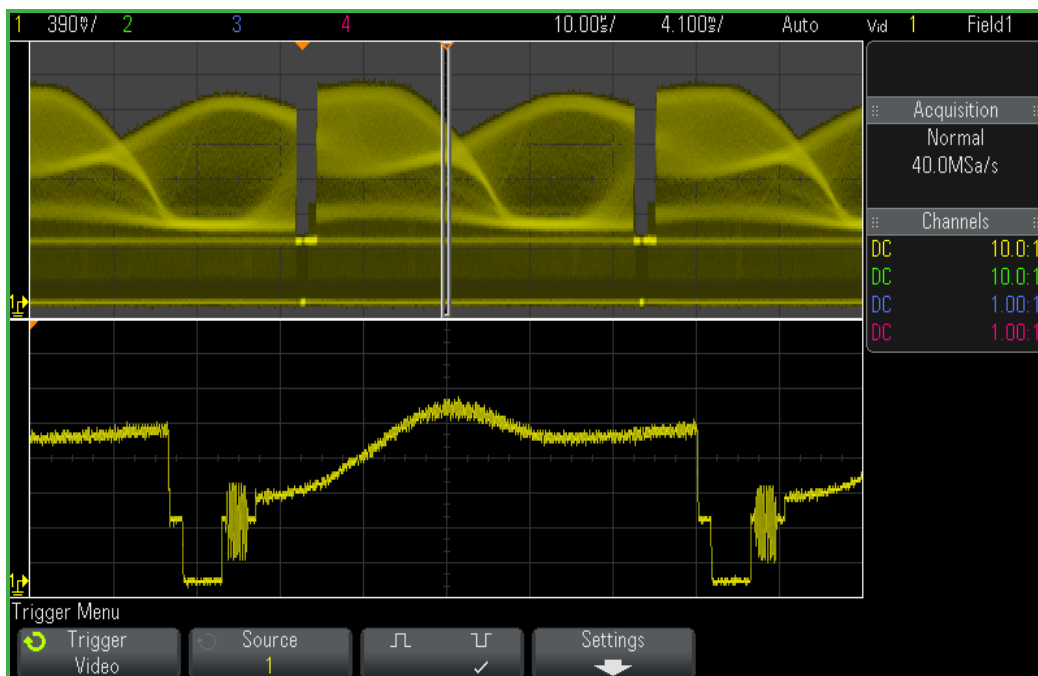

Figure 19. You need high levels of display quality when viewing complex modulated signals such as video

To learn more about oscilloscope display quality, refer to the Keysight application note [Oscilloscope Display Quality Impacts Ability to View Subtle Signal Details](#).

## Tip #8: Serial Bus Applications

### Select an oscilloscope that can trigger on and decode serial buses to help you debug your designs faster

Serial buses such as I<sup>2</sup>C, SPI, RS-232 / UART, CAN, and USB, are pervasive in many of today's digital and mixed-signal designs. Verifying proper bus communication along with analog signal quality measurements requires an oscilloscope. Many engineers and technicians verify serial bus communication with an oscilloscope using a technique known as "visual bit counting." But this manual method of decoding a serial bus can be time-consuming and error-prone. However, many of today's DSOs and MSOs have optional built-in serial bus protocol decode and triggering capabilities. If your designs include serial bus technology, then selecting an oscilloscope that can decode and trigger on these buses can help you debug your systems significantly faster.

Most oscilloscopes that have serial bus analysis capabilities use software-based decoding techniques. With software-based decoding, waveform and decode update rates tend to be slow (sometimes seconds per update). This is especially true when using oscilloscopes with deep memory, which must often capture multiple packetized serial bus signals. And when analyzing multiple serial buses simultaneously, software techniques can make protocol-specific decode update rates even slower.

Keysight's InfiniiVision X-Series oscilloscopes use hardware-based decoding to provide virtual real-time updates. Faster decoding with hardware-based technology enhances oscilloscope usability and, more importantly, the probability of capturing infrequent serial communication errors.

Figure 20 shows a Keysight InfiniiVision X-Series oscilloscope capturing and decoding a controller area network (CAN) serial bus, common in automotive and industrial machinery applications, including medical diagnostics equipment. Below the waveform is the time-correlated decode trace that shows the contents of a single packet / frame of data. The upper half of the oscilloscope's display shows the "lister" display, which provides decoded information in a more familiar tabular format, like a traditional protocol analyzer. The lister display can also search and automatically navigate to specific packets of interest.

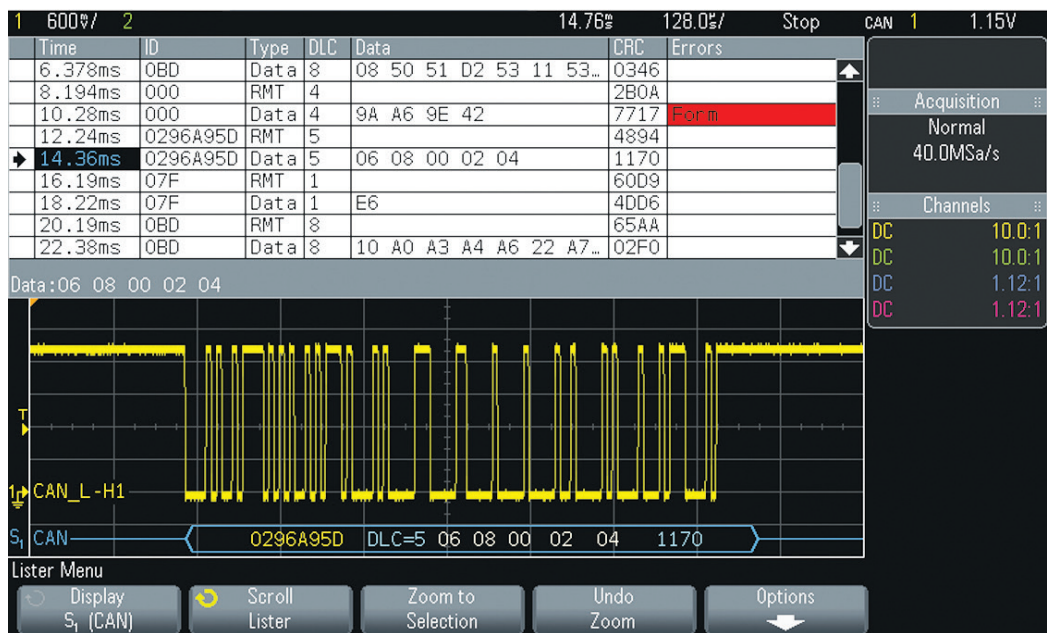

Figure 20. Triggering on and decoding a CAN serial bus using a Keysight InfiniiVision X-Series oscilloscope

In addition to triggering on and decoding serial buses, it is often necessary to perform eye-diagram mask test measurements on serial bits. This is especially important for higher-speed differential buses or buses that communicate over a long network. With an eye-diagram display, all serial bits are overlaid and compared to a pass / fail mask based on published industry physical layer standards and specifications. Figure 21 shows an eye-diagram mask measurement on a CAN serial bus, which is common in today's automobiles. With a mask test rate of up to 200,000 waveforms / sec, the scope quickly captures bits that exhibit excessive jitter, as shown by the traces in red.

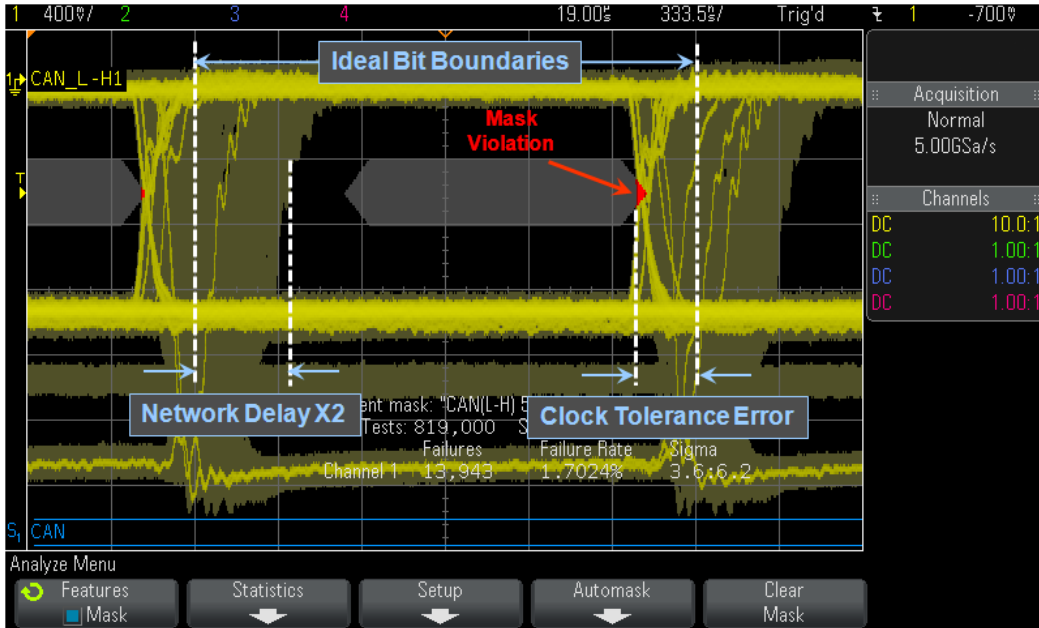

Figure 21. Eye-diagram mask test on a CAN serial bus using a Keysight InfiniiVision X-Series oscilloscope

Keysight's InfiniiVision and Infiniium Series oscilloscopes offer a broad range of serial bus protocol trigger / decode options, including the following:

- I<sup>2</sup>C / Quad SPI
- RS-232 / UART
- USB
- CAN / CAN FD / LIN
- SENT
- FlexRay
- I<sup>2</sup>S
- MIL-STD 1553 / ARINC 429 / SpaceWire
- JTAG (IEEE 1149.1)
- MIPI<sup>®</sup> D-PHY<sup>SM</sup>
- PCI Express<sup>®</sup>
- SATA
- SVID
- Ethernet
- I3C
- SPMI
- 100BASE-T1 Automotive Ethernet
- CXPI
- PSI5 / Manchester
- NFC

Many higher-speed serial buses such as USB, PCIe, and Gigabit Ethernet require automatic pass / fail compliance testing against published industry standards and specifications. Keysight's Infiniium oscilloscopes offer a broad range of optional compliance test packages. Figure 22 shows an automated PCIe Gen 5 compliance test using a Keysight Infiniium Series oscilloscope. Complete report generation is also available with the various compliance test packages.

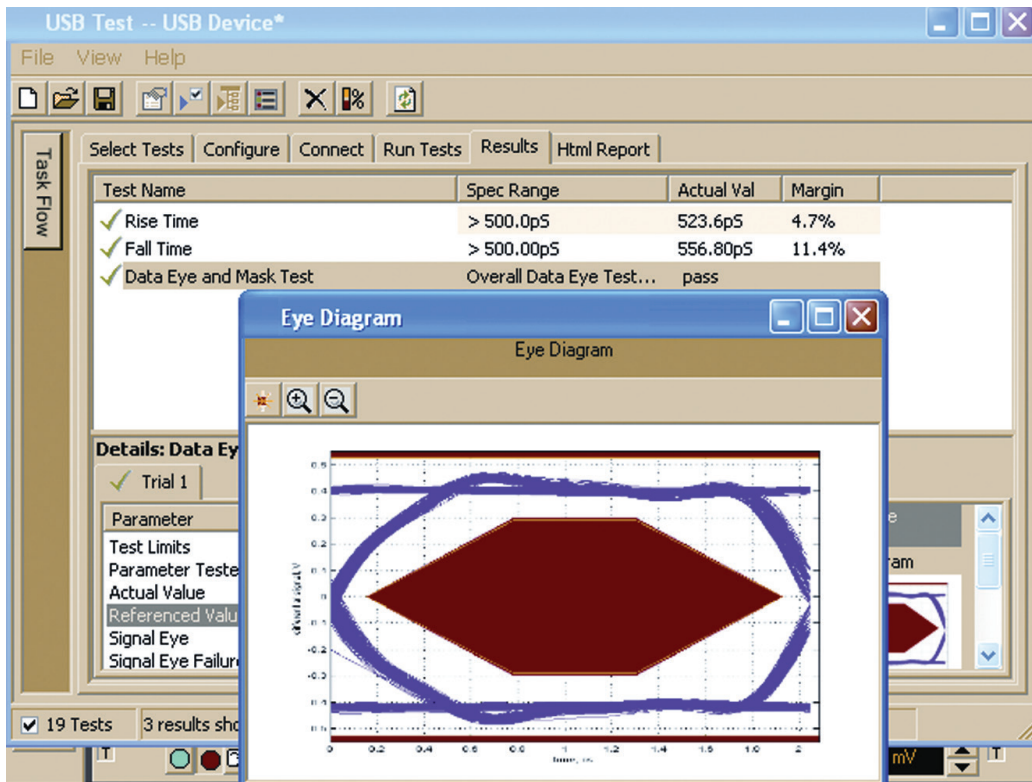

Figure 22. USB 2.0 high-speed compliance test performed using a Keysight Infiniium Series oscilloscope

To learn more about oscilloscope serial bus applications, refer to the Keysight data sheet [Serial Bus Options for InfiniiVision X-Series Oscilloscopes](#).

## Tip #9: Measurements and Analysis

Select an oscilloscope that can automatically perform your required parametric measurements and waveform math operations so you can characterize your designs faster

One major advantage of today's DSOs over older analog oscilloscope technology is that they can perform various automatic measurements and analysis on digitized waveforms. You will find that digital oscilloscopes from different vendors have a wide variety of measurement capabilities. But nearly all of today's DSOs provide manually controlled cursor / marker measurement capabilities, as well as a minimum set of automatic pulse parameter measurements such as rise time, fall time, frequency, pulse width, as shown in Figure 23.



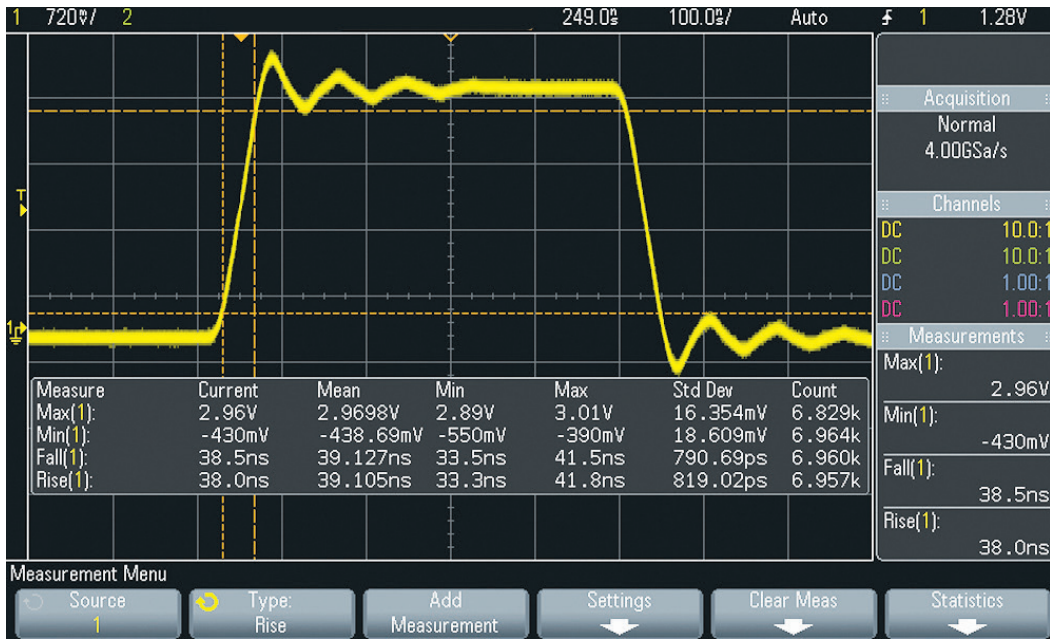

Figure 23. Performing automatic parametric amplitude and timing measurements using a Keysight oscilloscope

As you move up in price and performance, you will find that higher-end oscilloscopes typically have more measurement and analysis capabilities. Those capabilities include advanced waveform math, automatic pass / fail mask testing, RF measurements, and application-specific compliance testing.

Pulse parameter measurements typically perform a timing or amplitude measurement across a small portion of a waveform to provide an “answer,” such as the rise time or peak-to-peak voltage. An oscilloscope’s waveform math function, however, performs a math operation on an entire waveform or pair of waveforms to produce yet another waveform.

Figure 24 shows an example of a fast Fourier transform (FFT) math function performed on a clock signal (yellow trace). This produced the frequency domain waveform (purple trace) that shows amplitude in decibels on the vertical axis versus frequency in hertz on the horizontal axis. Other common math operations that you can perform on digitized waveforms include sum, difference, differentiate, and integrate.

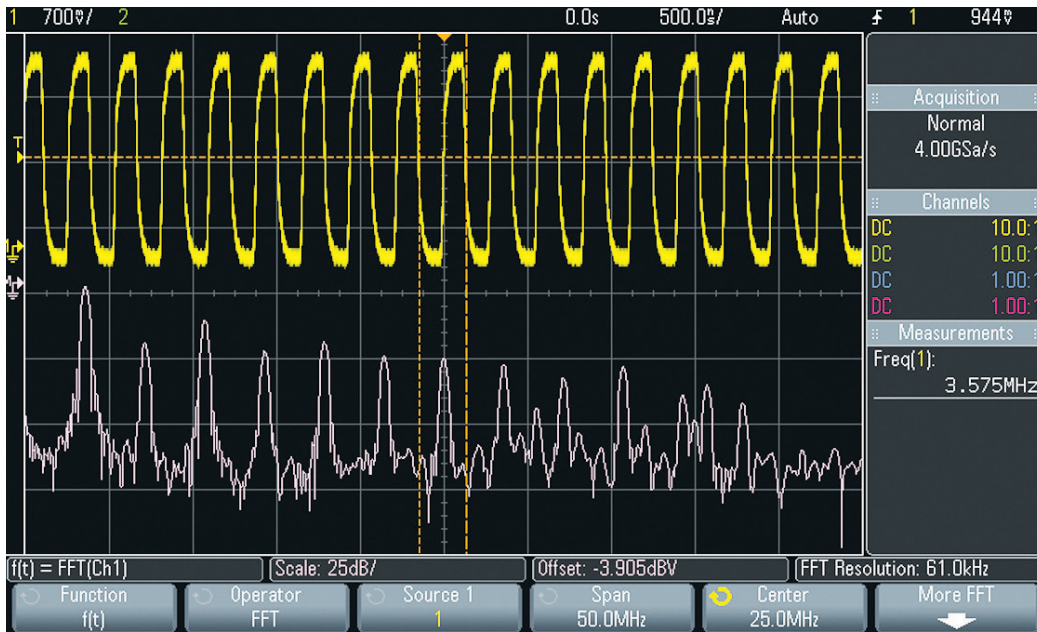

Figure 24. Performing an FFT math operation on a digital clock waveform using a Keysight oscilloscope

You can perform most advanced waveform math functions offline on a PC using software such as MATLAB. But having this capability embedded in the oscilloscope makes it easier to perform these advanced math functions. It can also provide an updated display of waveform math functions that show dynamic signal behavior.

Some of today's oscilloscopes can also perform automatic pass / fail testing based on published industry standards and specifications. Figure 25 shows an example of a pass / fail current harmonics compliance test on a switch mode power supply (SMPS) using an optional Power Measurements analysis package. If any harmonics of the input signal (up to the 40th harmonic) exceed specified standards, they are clearly marked in the test results table shown in the upper half of the oscilloscope's display.

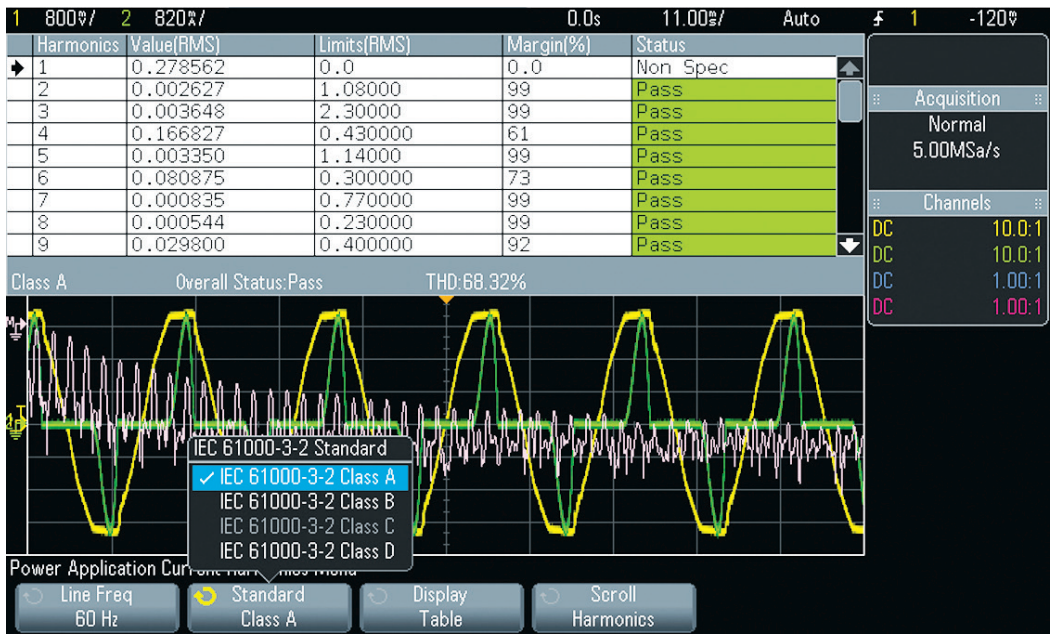

Figure 25. Automatic pass / fail compliance testing using a Keysight oscilloscope

Some oscilloscopes can also perform frequency response analysis. This is an often-critical measurement used to characterize the frequency response (gain and phase versus frequency) of a variety of today's electronic designs, including passive filters, amplifier circuits, and negative feedback networks of SMPS (loop response).

Keysight's InfiniiVision oscilloscopes can use their built-in waveform generator (WaveGen) to stimulate the circuit under test at various frequency settings and capture the input and output signals using two channels. At each test frequency, the oscilloscope measures, computes, and plots gain ( $20\log V_{out} / V_{in}$ ) and phase logarithmically.

To learn more, watch the video [How to Perform Frequency Response Analysis on an Oscilloscope](#).

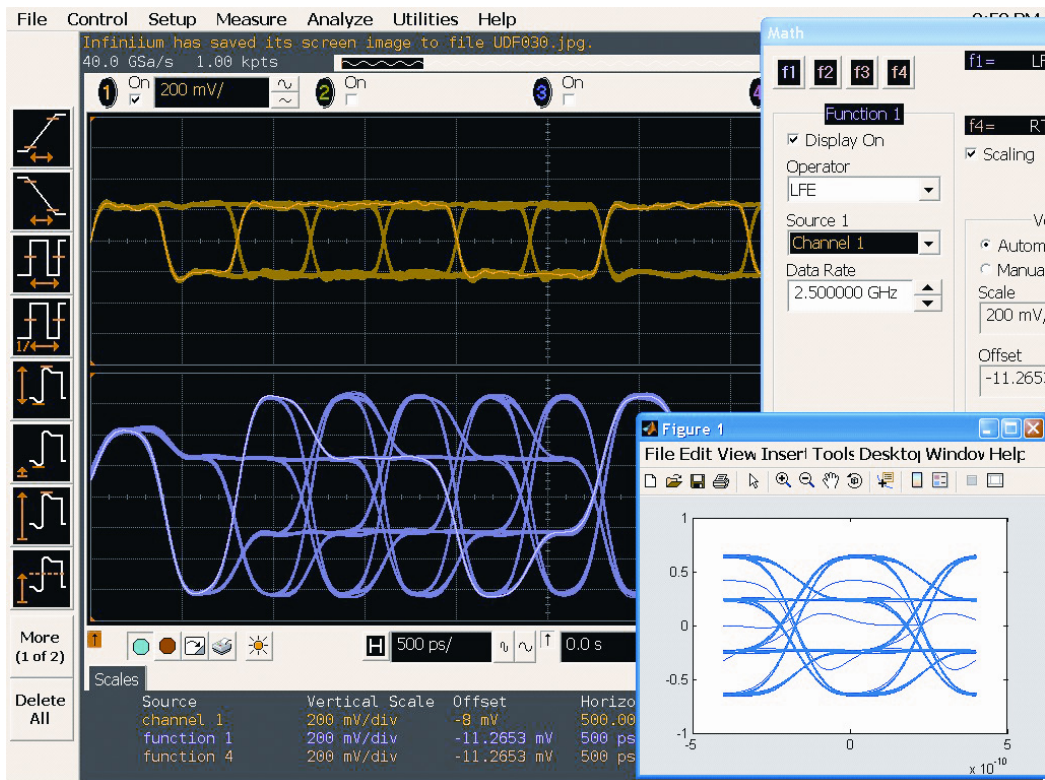

Figure 26. Frequency response analysis plot (Bode gain and phase) of a bandpass filter

## Tip #10: Connectivity and Documentation

### Select an oscilloscope that meets your hardware connectivity, test automation, and electronic documentation requirements

Many automated test environments in both R&D and manufacturing rely on digital oscilloscopes. Automated testing requires that you connect the oscilloscope to a computer via a connectivity port. Most older DSOs use only GPIB or RS-232 connectivity. Most of today's DSOs and MSOs use USB or LAN connectivity. If you need to use your oscilloscope in an automated test environment, make sure the one you select has the required hardware connectivity ports and is fully programmable. In other words, make sure any measurement that can be performed using the oscilloscope's front panel and menu controls can also be programmed remotely.

Keysight's InfiniiVision X-Series and Infiniium Series oscilloscopes are all fully programmable via SCPI commands as well as National Instruments IVI drivers.



Figure 27. Automated test rack

When you perform manual oscilloscope measurements on the bench, it is important to document and save test results. One method of documenting test results is to send a screen image to a printer connected directly to the oscilloscope. But a more common method of documenting test results is to save data. In addition to being able to transfer data to a PC via a direct USB or LAN connection, most digital oscilloscopes can save images and waveform data in various formats directly to a USB memory stick, as shown in Figure 28. You can then easily import saved images (screenshots) and data (waveforms) into various word processors, spreadsheets, and applications such as MATLAB.

Keysight's **Infiniium Offline** software lets you easily capture waveforms on your oscilloscope, save them to a file, and recall the waveforms into the application.



**Figure 28.** Quickly and easily save waveform data and screen-shots to you personal USB drive.

Some of today's digital oscilloscopes even have built-in web browsers. This makes it easy for engineers to access "live" oscilloscope measurements that may reside in another part of the world. For instance, Figure 29 shows an example of an engineer in his US office remotely controlling and making measurements on an oscilloscope connected to a device under test (DUT) in China.

**Figure 29.** The built-in web browser of Keysight's InfiniiVision, with a virtual remote front-panel user interface, makes it easy to control and access "live" oscilloscope measurements from anywhere in the world



## Tip #11: Probing

### Select an oscilloscope from a vendor that can provide the variety of specialty probes you may require

Your measurements are only as good as the information your probe delivers to the oscilloscope's BNC inputs. When you connect any kind of measurement system to your circuit, the instrument (as well as the probe) becomes part of your DUT. This means it can “load” or change the behavior of your signals to some degree. Good probes should not disturb the input signal and should deliver an exact duplicate of the signal that was present at the probe point before the probe was attached.

When you purchase a new oscilloscope, it typically comes standard with a set of high-impedance passive probes — one probe for each input channel of the oscilloscope. These types of general-purpose passive probes are most common and enable you to measure a broad range of signals relative to ground. But these probes have limitations. Figure 30 shows an electrical model of a typical 10:1 passive probe connected to the high-impedance input (1 M $\Omega$  input of an oscilloscope).

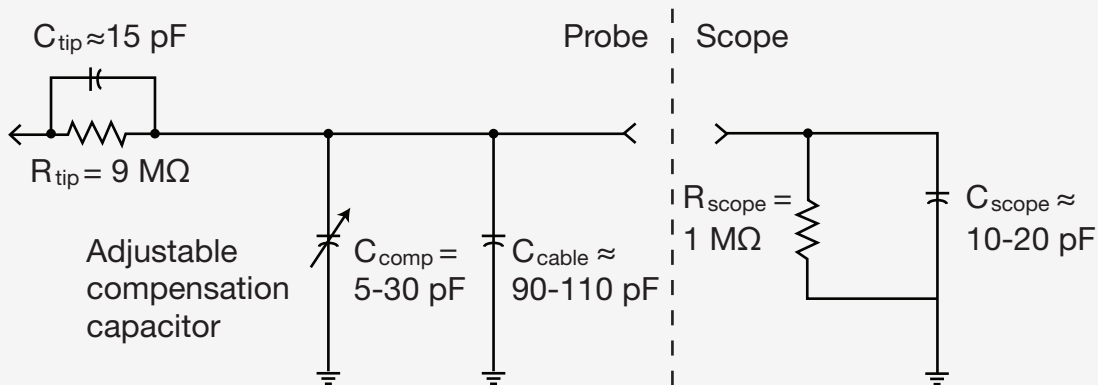

Figure 30. Typical model of a 10:1 passive probe

Inherent in all oscilloscope probes and inputs are parasitic capacitances. These include the probe cable capacitance ( $C_{cable}$ ) and the oscilloscope's input capacitance ( $C_{scope}$ ). “Inherent / parasitic” simply means these elements of the electrical model are not part of the actual design but are an unfortunate fact of life in the real world of electronics. The amount of inherent / parasitic capacitance will vary from oscilloscope to oscilloscope and probe to probe. Also included in this electrical model are designed-in capacitive elements that compensate for low-frequency pulse response.

The electrical model of any probe (passive or active) and oscilloscope can be simplified down to a parallel combination of a single resistor and a single capacitor. Figure 31 shows a typical oscilloscope / probe loading model for a 10:1 passive probe. This is essentially what you connect in parallel with your DUT when making oscilloscope measurements with a probe. For low-frequency or DC applications, the 10 M $\Omega$  resistance dominates loading, which in most cases should not be a problem. Although 13.5 pF may not sound like much capacitance, at higher frequencies the amount of loading it contributes can be significant. For instance, at 500 MHz the reactance of 13.5 pF in this model is just 23.6  $\Omega$ , which could contribute to significant “loading” and signal distortion.

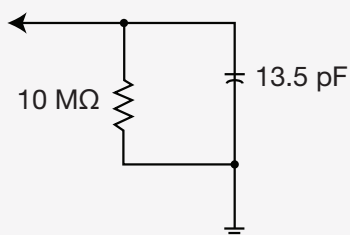

Figure 31. Simplified probe / oscilloscope electrical model

For higher-frequency measurement applications, you should use active probes, such as Keysight’s InfiniiMode Series differential active probe, shown in Figure 32. “Active” means that the probe consists of an amplifier near the tip. This can significantly reduce the amount of capacitive loading and increase probing bandwidth. But the trade-offs with high-frequency active probes are often lower dynamic range and price.



Figure 32. Keysight’s InfiniiMode Series differential active probe

Besides high-frequency active probes, you should consider many other specialty probing applications. If you need to make measurements on a high-speed differential serial bus, then consider using a high-frequency differential active probe. If you need to make measurements on very high voltage signals, consider using a high-voltage probe. If you need to make current measurements, consider using a current probe.

To learn more about oscilloscope probing, refer to Keysight's [Eight Hints for Better Scope Probing](#) application note.

Keysight offers a broad range of passive, active, differential, and current probes that will meet your particular probing measurement needs. Refer to the Keysight probes data sheets listed at the end of this document to learn more about Keysight's various probing solutions.

## Tip #12: Ease of Use

### Select an oscilloscope that can improve your measurement productivity with an intuitive user interface

Ease of use. Usability. User friendly. Intuitive. These are important oscilloscope characteristics. Although we have addressed ease of use last in our list of 12 tips, sometimes the usability of an oscilloscope can be as important as specified performance characteristics, such as bandwidth, sample rate, and memory depth.

As oscilloscope vendors have packed more and more advanced features and capabilities into digital storage oscilloscopes, many engineers believe they have become difficult to use. A new oscilloscope may have an advanced measurement capability that is meant to improve measurement productivity. However, if that feature is too difficult to find because it is buried deep in a submenu of the oscilloscope or if it is too difficult to set up because it includes advanced settings that the user doesn't understand, most engineers will simply grab the old oscilloscope off the shelf to perform the measurement.

Although most oscilloscope vendors will claim that their oscilloscopes are the easiest to use, usability is not a specified parameter that you can compare against in a product's data sheet. Ease of use is subjective, and you must evaluate it for yourself. Of course, the easiest oscilloscope for you to use is probably the one that you are already using. This is simply because you are familiar with it and may be hesitant to change. This is human nature, though it is worth looking into how vendors have improved usability to make your job easier and faster.

The following are some important usability factors that we believe you should consider.





## Knobs

Engineers like knobs on their oscilloscopes. Oscilloscopes should have knobs that directly control all key variables, including vertical scaling (v / div), vertical position, timebase scaling (s / div), horizontal position, and trigger level, as shown in Figure 33. Some oscilloscopes have multiplexed knobs, such as just one set of vertical scaling knobs, as opposed to scaling knobs for each input channel. Some oscilloscopes also “bury” key variables such as horizontal position or trigger level within menus.

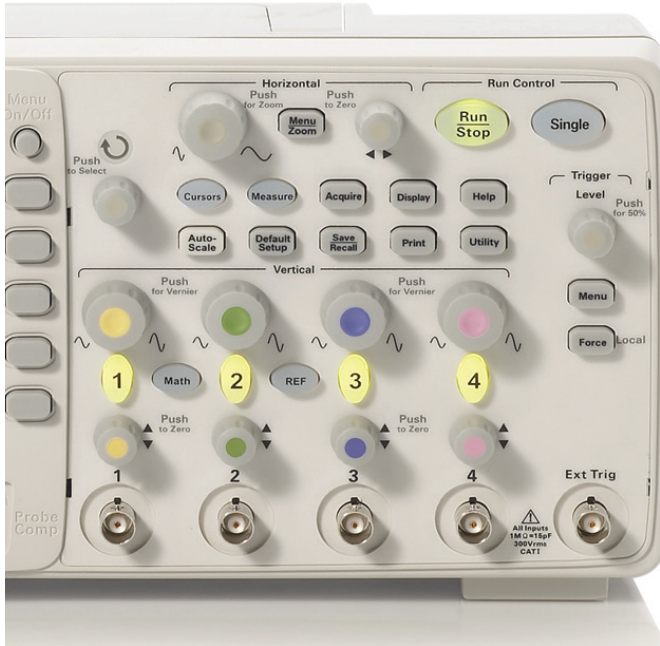

Figure 33. Oscilloscope front panels should include knobs for all key setup variables

## Responsiveness

Responsiveness is important. Setting up an oscilloscope is often a random and iterative process. Turn this knob, turn that knob, turn another knob until you properly scale the waveform on the screen. But if the oscilloscope is unresponsive because it’s busy processing captured data from the previous acquisition, setting it up can be a frustrating experience.

## Built-in help

Turning on and using advanced features shouldn’t require an advanced degree. Engineers are reluctant to read manuals and user’s guides, even if they could find them. Some oscilloscopes have built-in help screens that provide short setup tips about specific features. For example, on many Keysight oscilloscopes, you can access built-in help by pressing and holding down any front-panel key or menu button. Figure 34 shows a Keysight runt triggering help screen.

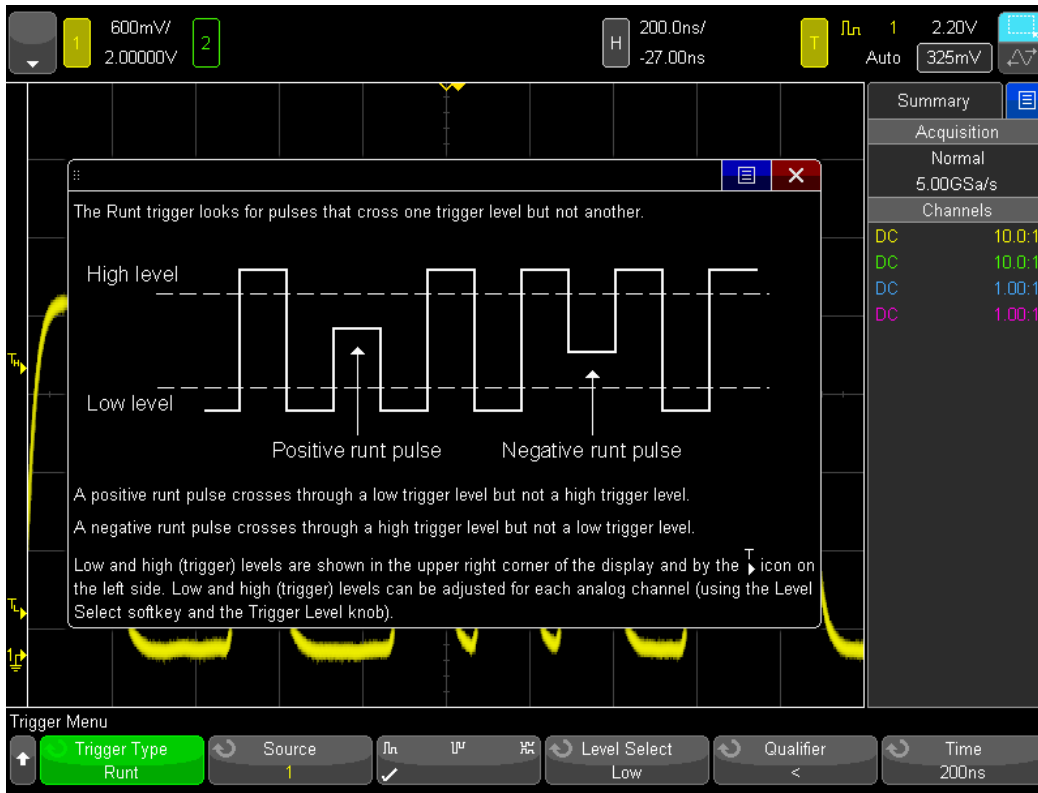

Figure 34. Built-in help screens assist users in setting up advanced measurements

## Larger color displays

Today's oscilloscopes can display lots of measurement information besides waveforms. Larger displays with color can help clear the clutter so your eyes can focus on what's most important.

Keysight has found some innovative ways to use touchscreen technology to improve oscilloscope usability, such as zone touch triggering, which is available on the InfiniiVision 3000T, 4000, and 6000 X-Series. It uses the same capacitive-touch technology found in tablet computers on the market today. Simply use your finger to draw a box around the waveform that you want to trigger on, and the oscilloscope triggers on that unique signal without the hassle of setting up a complex trigger condition.



Figure 35. The 4000 X-Series oscilloscope's touch screen and zone touch trigger help you quickly set up complex trigger conditions

## Keysight's InfiniiVision and Infiniium Series Oscilloscopes

### InfiniiVision X-Series oscilloscopes

Keysight's **InfiniiVision 1000 X-**, **2000 X-**, **3000T X-**, **4000 X-**, and **6000 X-Series oscilloscopes** are optimized for benchtop debug and troubleshooting. They come in bandwidth models ranging from 70 MHz to 6 GHz. With the fastest waveform update rates in the industry (up to 1,000,000 waveforms per second), these oscilloscopes can capture and display infrequent signal anomalies that other oscilloscopes miss.



## Infiniium Series oscilloscopes

Keysight's higher-performance **Infiniium MXR-, UXR-, S-Series, V-Series, and Z-Series oscilloscopes** are Windows-based instruments that are optimized for advanced waveform analysis. They come in bandwidths ranging from 500 MHz up to 110 GHz. The Infiniium Series oscilloscopes also have the deepest available acquisition memory in the industry (up to 2 Gpts). Also available on these oscilloscopes is a wide range of industry-standard compliance test packages, as well as advanced measurement options such as jitter analysis.

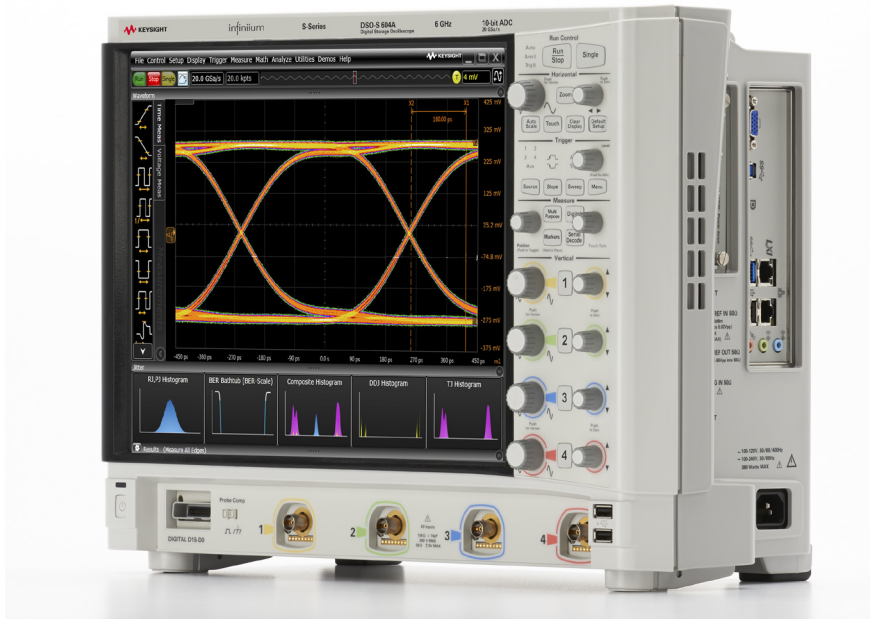



Learn more at: [www.keysight.com](http://www.keysight.com)

For more information on Keysight Technologies' products, applications or services, please contact your local Keysight office. The complete list is available at: [www.keysight.com/find/contactus](http://www.keysight.com/find/contactus)



Find us at [www.keysight.com](http://www.keysight.com)

This information is subject to change without notice. © Keysight Technologies, 2013 - 2020, Published in USA, June 24, 2020, 5991-2714EN

Page 37